

## Smart Automation Using Tongue Motion

**Aman Agrawal<sup>1</sup>, Adarsh Babu Varshney<sup>1</sup>, Manish Kumar Rai<sup>1</sup>, Himanshu Garg<sup>1</sup>**

<sup>1</sup>Student, Department of Electronics and Communication, IMS Engineering College Ghaziabad, UttarPradesh, India.

Corresponding author: aman145agrawal@gmail.com

**Abstract:** - This paper subtly the use of tongue movement concerning the control of moving wheel seat. The tongue drive framework is a tongue worked instrument Assistive Technology which is created for the individuals having serious handicap so as to control their condition. This framework has utilized exhibit of Hall Effect attractive sensors which are mounted on mouthpiece alongside the little perpetual magnet put on the tongue. These Hall Effect sensors are utilized to gauge the attractive field produced by the little changeless magnet. The detected signs are communicated by means of remote connection which is handled by microcontroller to control the development of wheelchair. In early days' numerous assistive innovations have been planned each structure had a few bad marks. This paper gives a proficient, simple entry, minimal effort answers for all the negative marks experienced in past plans.

**Key Words:** —Tongue Drive, Hall Effect, Mouth Piece, Wheel Chair.

### I. INTRODUCTION

Assistive advancements are generally valuable for individuals with serious incapacities to lead their life a self-steady autonomous life. People seriously handicapped because of influences going from awful cerebrum and spinal string wounds to stroke discover it very hard to complete ordinary errands without nonstop assistance. Assistive advances that would assist them with conveying their goals and viably control their condition, particularly to work a wheelchair, would improve the personal satisfaction for this gathering of individuals and may even assistance them to be utilized.

There are numerous assistive innovation gadgets that are accessible in the market constrained by switches [1]. The switch coordinated hand support, taste n-puff gadget, jaw control framework, and electromyography (EMG) switch are all switch based frameworks and furnish the client with constrained degrees of opportunity.

A gathering of head-mounted assistive gadgets has been built up that imitate a PC mouse with head developments. Cursor developments in these gadgets are constrained by following an infrared shaft radiated or reflected from a transmitter or reflector joined to the client's glasses, top, or headband. Tilt sensors and video based PC interfaces that can follow a facial element have additionally been executed. One impediment of these gadgets is that solitary those individuals whose head development is restrained may benefit of the innovation. Another constraint is that the client's head ought to consistently be in positions inside the scope of the gadget

sensors. For instance, the controller may not be available when the client is lying in bed or not sitting before a PC.

Another class of PC get to frameworks work by following eye developments from corneal reflections and understudy position. Electro-oculographic (EOG) potential estimations [2], [3] have additionally been utilized for distinguishing the eye developments. A significant constraint of these gadgets is that they influence the client's vision by requiring additional eye developments that can meddle with clients' typical visual exercises, for example, perusing, composing, and viewing.

The necessities of people with extreme engine handicaps who can't profit by mechanical developments of anyone organs are tended to by using electric signs began from mind waves or muscle jerks. Such mind PC interfaces, either intrusive, or non-obtrusive have been the subject of significant exploration exercises. Mind Gate [4] is a case of an obtrusive innovation utilizing intracortical terminals, while Cyberlink [5] is a non-intrusive interface utilizing anodes appended to the temple. These advances intensely depend on signal handling and complex computational calculations, which can bring about postponements or critical expenses. Think-a-Move Inner voice is one more interface innovation stage that banks on the abilities of the ear as a yield gadget. A little earpiece gets changes in pneumatic force in the ear trench brought about by tongue developments, discourse, or considerations. Signal preparing is utilized to make an interpretation of these progressions into gadget control orders.

## II. CONTRIBUTION

- There are a few targets associated with this task, they are as follow.
- To execute an assistive framework that can be constrained by tongue movement.
- To structure a framework which require low physical fixation to control.
- To make an arrangement for remote controlling framework.
- To study the utilization of remote RF innovation.

## III. LITERATURE SURVEY

### A. Sip-and-puff wheelchair

It was created in the mid1960s, and utilized a taste and-puff control component for the control of wheelchair. Taste and-Puff is assistive innovation used to impart signs to a gadget utilizing gaseous tension by "tasting" (breathing in) or "puffing" (breathing out) on a straw, cylinder or "wand." It is generally utilized by individuals who don't have the utilization of their hands. Sharp tastes and puffs can be utilized to alter the speed and course of the wheelchair. Directing is practiced by lower-level tastes and puffs. Be that as it may, this isn't useful for individual with week relaxing. A straightforward model for taste and-puff wheelchair is given as underneath.

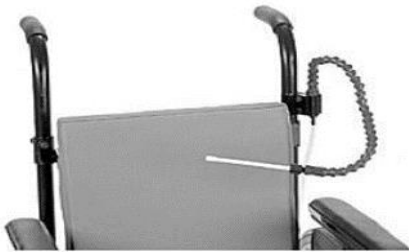

Fig.2.1. Sip-and-puff wheelchair

### B. Voice activated powered wheelchair

This paper builds up a practical voice actuated wheelchair, which resembles the figure 2 given underneath. Different interfaces to control fueled wheelchair are proposed. Since the voice is the most common correspondence ways for individual, our investigation focuses on discourse acknowledgment. The client controls the wheelchair by the intelligent activity. The wheelchair doesn't act dependent on bogus discourse acknowledgment. In any case, there is a

difficult that is the wheelchair crashes in the divider and impediment by deferring the voice order. At that point, our framework applies the impact shirking capacity CAF by which wheelchair maintains a strategic distance from the divider or on the other hand hindrance without voice order by utilizing the data of two sorts of sensor. CAF helps the client to control the wheelchair without crashing in the divider or snag. The viability of our framework was affirmed through the running test.

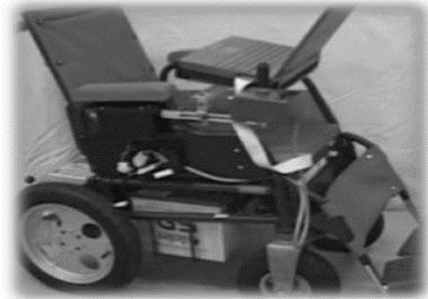

Fig.2.2. Voice activated powered wheelchair

### C. Head control wheelchair

A mechanized framework was created to control the engine pivot of a wheelchair dependent on the head development of an individual influenced by Quadriplegia. Individuals who are influenced by this illness can't move any of their body parts with the exception of their head. So as to encourage these individuals for their autonomous development, an accelerometer gadget is fixed on the brow. In view of the head development the accelerometer drives the engine associated with the wheel seat in any of the four bearings. The mechanized wheelchair depends on basic electronic control framework and the mechanical course of action that is constrained by a Programmable Interface Controller. The vehicle can be driven at a typical speed. This gadget additionally helps individuals who have different inabilities to sit on the seat and simply hold the accelerometer and move it over to control the vehicle developments. A model of head control wheelchair resembles the figure 3 as beneath.



Fig. 2.3. Head control wheelchair

#### D. Power wheelchair chin-operated force sensing joystick

A jaw worked power detecting controlled wheel seat joystick was created. On account of stick removal of customary position joystick, it is hard for the jaw worked wheelchair clients to work fueled wheelchair. Contrasted with the customary position detecting joystick, individuals utilizing a jawline worked power detecting joystick don't have to move their head rapidly and precisely. They simply need to provide a little unique guidance power to the joystick stick. The power detecting joystick shaft is put forth of defense solidified steel, the region for strain gages was machined level. The length and width of the pole was intended to display a strain reaction in the direct working scope of the strain measures. The powers expected to control a controlled wheelchair are 0.2~0.8 pounds. The equipment and programming plan technique for the jaw worked power detecting joystick were presented in the paper.



Fig.2.4. Power wheel chair chin-operated force sensing joystick

#### IV. PROPOSED SYSTEM DESIGN

In the Tongue movement controlled framework, the movement of the tongue is followed by a variety of Hall-impact attractive sensors, which measure the attractive field produced by a little changeless magnet that is contained inside a nonmagnetic installation and punctured on the tongue. The attractive sensors are mounted on a dental retainer and connected outwardly of the teeth to gauge the attractive field from various points and give persistent continuous simple yields. Figure 5 shows the Tongue Drive framework square chart with two significant units: one inside the mouth, the mouthpiece, and the other outside, a convenient body worn controller. Little batteries, for example, listening device button-sized cells are proposed to control the mouthpiece for stretched out spans as long as a month. The force the executive's hardware looks over the sensors and turns them on each in turn to spare force. The time division multiplexed (TDM) simple yields are then digitized, regulated, and sent to the outside controller unit over a remote connection.

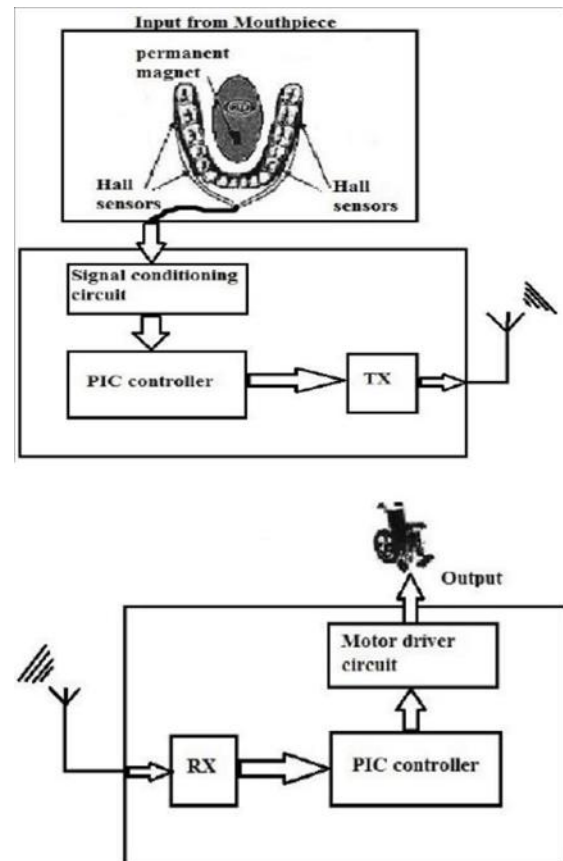

Fig.3.1. Simplified block diagram of the Tongue Drive system

The signs got by the outside controller unit are demodulated and de-multiplexed to extricate the individual sensor yields. By preparing these yields, the movement of the lasting magnet and thus the tongue inside the oral depression is resolved. Doling out a specific control capacity to every specific tongue development is done in programming and can be handily modified for every individual client. These tweaked control capacities may then be utilized to work an assortment of gadgets and gear's including PCs, telephones, and controlled wheelchairs.

#### V. IMPLEMENTATION

The entire square outline is separated into two areas which are Transmitter and Receiver.

##### A. Transmitter block diagram

Above fig shows the outline of the transmitter. This uses four Hall Effect Sensors, interfaced to the microcontroller. Lobby

Effect sensors are transducer whose yield voltage fluctuates in light of the change in attractive field.

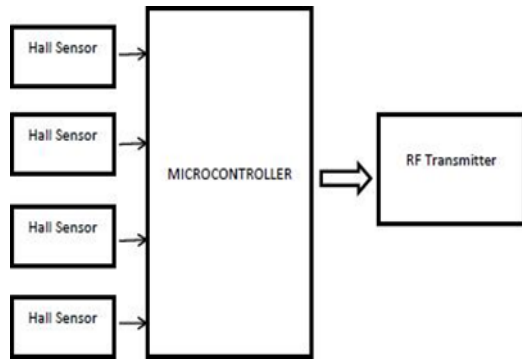

Fig.4.1. Transmitter block diagram

Four Hall Effect Sensors are utilized to control the course of moving wheelchair. As the magnet is carried near a specific Hall Effect sensors the sensors gets initiated, and as the attractive field is evacuated Hall Effect sensors gets deactivated. In view of which Hall Effect sensors is enacted microcontroller takes a specific choice with respect to which heading the wheelchair should move. The RF transmitter imparts the specific choice sign to the recipient circuit.

### B. Transmitter circuit diagram

The framework utilizes four Hall Effect sensors and is associated with pins P1.0, P1.1, P1.2 and P1.3 of ATMEL AT89S52 microcontroller. With the goal that Port 1 of microcontroller is made as input Port. The yield of Hall Effect sensor is extremely less to be identified by the microcontroller. To take care of this difficult draw up resistors are utilized alongside every Hall Effect sensor. Which bring about increment of yield voltage level to 5v each. With no attractive field, the yield and VCC terminals of the corridor impact sensors are pulled up to vcc. At the point when a magnet is brought close to a specific Hall Effect sensor, a corridor sensor gets enacted and the yield gets pulled down to ground. Pins P0.1, P0.2, P0.3 and P0.4 are associated with the RF transmitter for sending the controlling guidance of the wheelchair.

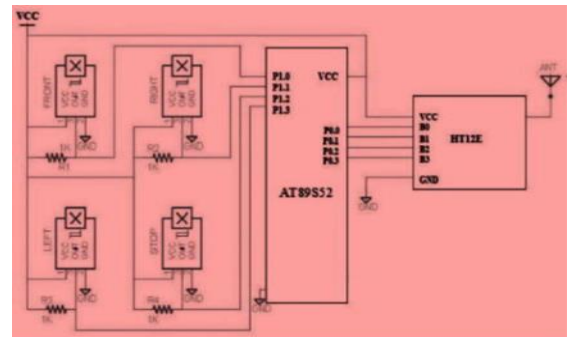

Fig.4.3. Transmitter circuit diagram

### C. Receiver block diagram

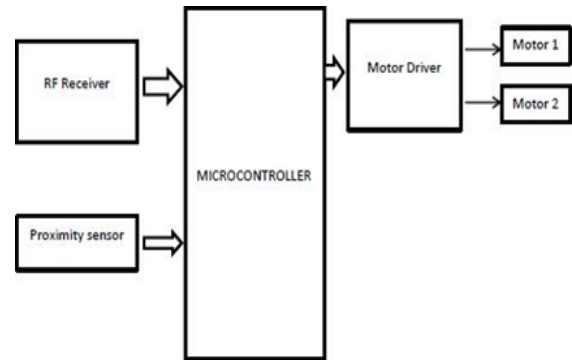

Fig.4.2. Receiver block diagram

Above block diagram shows the receiver part of the system. The choice made by the microcontroller in the transmitter hardware is gotten through the RF collector which is interfaced to the microcontroller as appeared in the above fig. The engines are associated with the microcontroller utilizing a H-Bridge engine driver. The engine driver is utilized to control the headings of both the engines utilized. In view of the choice communicated, the wheelchair is moved a particular way by controlling the engine's heading. To keep the wheelchair from crash into divider, obstructions a closeness sensor is associated. In light of the nearness sensor yield, the microcontroller chooses for the emergency stop.

The RF receiver is associated with pins P2.0, P2.1, P2.2 and P2.3 of the ATMEL AT89S52 microcontroller. The RF receiver gets the choice for controlling the wheelchair which was sent by the RF transmitter utilizing bit pattern.

#### D. Receiver circuit diagram

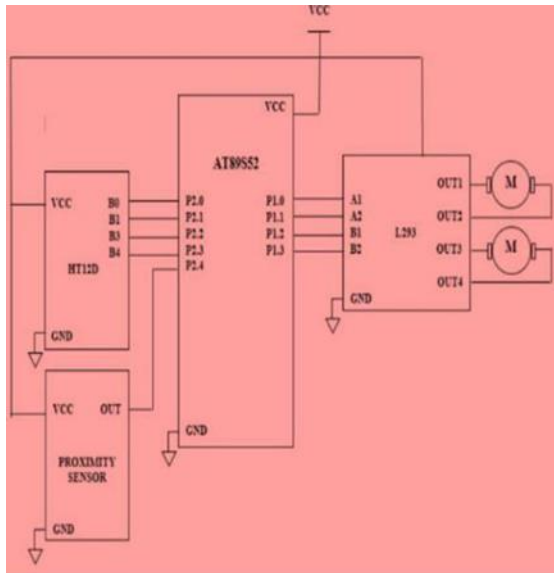

Fig. 4.4. Receiver circuit diagram

In this way, we design Port 2 as info port. Pins P1.0, P1.1, P1.2 and P1.3 of the microcontroller is associated with pins A1, A2, B1 and B2 of the H-connect driver which is utilized to control the course of the engines of the fueled wheelchairs. Since two engines are utilized it requires two h-connect drivers. Subsequently, we are utilizing L293d where A1 and A2 are the control pins of engine A though B1 and B2 are controls pins of engine B. Since we are utilizing the H-connect drivers in L293d IC, we interface both empower pins of the IC to VCC. The yield pins of the H-connect drivers are associated with the engines. For the discovery and treatment of impact reason nearness sensor is associated with P2.4 of the microcontroller. The vicinity sensors give a yield of 5v on the off chance that it draws close to any hindrances. Along these lines, microcontroller is programed in such an approach to accomplish the activity.

#### VI. ADVANTAGE & DISADVANTAGE

This system has many advantages some of them are as follows,

- It helps the physically challenged persons to carry out their daily life.
- It is simple to implement, low cost, easy to operate flexible.

- Only a few sensors are able to capture a wide verity of tongue movements.
- It has adoptive control over the environment.
- Requires very less concentration.
- No surgery needed for placing the sensors.
- It offers better privacy to the user as it is placed inside the mouth.
- Require low power for operation.

This system also has few disadvantage and they are,

- Users must avoid inserting ferromagnetic objects in their mouth.
- Users should avoid using ferromagnetic items near mouth as signal may be interfered.
- At the time of MRI scan magnetic tracer need to be removed.

#### VII. CONCLUSION

A tongue movement controlled magnetic sensor based remote assistive innovation framework has been actualized and produced for the clients with serve handicaps to lead their life as a self-steady and autonomously by utilizing AT framework, to control their condition. This current framework's working rule is, it tracks the developments of perpetual magnet which is place on tongue using a grouping of a variety of Hall Effect sensors. Recorded information is sent through remote and later utilized for control. Along these lines by giving speedier, smoother and progressively advantageous reaction contrasting with the current AT System.

#### REFERENCES

- [1]. X. Xie, R. Sudhakar, and H. Zhuang, "Development of communication supporting device controlled by eye movements and voluntary eye blink," IEEE Trans. Syst., Man and Cybern., vol. 25, no. 12, 1995.
- [2]. J. Gips, P. Olivieri, and J.J. Tecce, "Direct control of the computer through electrodes placed around the eyes," Human-Computer interaction: Appl. And case studies, Elsevier, pp. 630-635, 1993.
- [3]. Rich D. Fan, "Home care sip-and-puff mechanism control" September 30, 2009.
- [4]. Murai A., Tottori Univ, Saitoh. T., "Voice activated wheelchair with collision avoidance using sensor information" ICCAS-SICE, 2009.

- [5]. Manogna, Vaishnavi, S.; Geethanjali, B. “Head Movement Based Assist System for Physically Challenged” Dept. of Bio-Med. Eng., Anna University 2011.
- [6]. Songfeng Guo; VA Rehabilitation Res. &Dev. Centre, “Development of power wheelchair chin-operated force-sensing joystick” VA Rehabilitation Res. & Dev. Centre, Univ. of Pittsburgh Monika Jain, “Tongue Operated Wheelchair for Physically Disabled People” International Journal of Latest Trends in Engineering and Technology (IJLTET), Vol. 4 Issue 1 May 2014.